

TITAN TOOL

100 SERIES[®] CONTROLLED-TORQUE STUD DRIVER

1. Drives studs to pre-determined torque.
2. Prevents stud or part damage when driving to shoulder or bottom of hole.
3. Quick releasing, non-reversing design assures high speed stud driving production.
4. Heavy duty design for larger stud sizes.

Excellent results on:

- Power Hand Tools
- Single or multiple spindle units
- Semi- or fully automatic assembly machines

Features:

- Two tool sizes covering 3/8" thru 1-1/8" and M10 thru M30 stud sizes
- Posi-Load[®] stud retainer for "automatic stud pick-up"

NOTE:

For smaller stud sizes refer to TITAN SENTINEL[®] stud driver brochure



100 SERIES CD[®] CONTROLLED-TORQUE STUD DRIVER



100 SERIES CD[®] stud driver shown with POSI-LOAD[®] stud retainer

100 SERIES CD[®] CONTROLLED-TORQUE STUD DRIVER

TITAN 100 SERIES CD Controlled Torque stud drivers are designed to drive larger diameter studs (3/8" to 1-1/8" or M10 to M30) to a predetermined torque. They automatically grip and release the stud without screwing on or off and, therefore, are 50% faster than reversing type stud drivers. Their time proven design assures the ultimate in reliability and efficiency.

PREDETERMINED CONTROLLED TORQUE

Studs have been driven to their maximum possible depth (either to the bottom of hole or until the shoulder on stud is flush with casting.) The

NOTE POSITION OF STUDS:

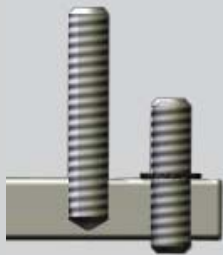

TITAN 100 SERIES CD Controlled Torque stud drivers is designed to drive studs to this point, at which time the clutch overruns, producing an audible torque tone, signalling the operator to lift the tool from the stud. Since the clutch is free-wheeling at this point and, because the CD is self-opening, it is not necessary to stop or reverse rotation.

EASY TORQUE ADJUSTMENT

The torque setting is easily adjusted by removing two allen screws in the adjusting nut and moving it downward for increased torque or upward for decreased torque. In any torquing operation, steps should be taken to protect the operator from increased torque reaction as the amount of torque is increased.

THE POSI-LOAD[®] STUD RETAINER



1. Eliminates the need to pre-start stud into casting.
2. The stud may be inserted by hand, by automatic feed or by shuttle plate.
3. Enables operator to pre-load stud driver quickly and simply without danger. (There is no torque on the stud when it is inserted into the Posi-Load only).
4. Pins provide positive grip on stud.

POWER SOURCE

TITAN 100 SERIES CD Controlled Torque stud drivers are adaptable to any power source, except impact wrenches

RECOMMENDED RPM		
#102 CD-400	#103 CD-300	#104 CD-200

When used on rigid spindles the spindles should be spring loaded. TITAN TOOL COMPANY makes available the TTSL spring loaded spindle adaptor for this purpose. Please refer to Multiple Spindle instruction sheet for further information on the proper set up of single or multiple spindle stud driving units.

The stud driver should be parallel to, and in line with, the stud at all times during the drive and retraction cycles.

TOOL MAINTENANCE

TITAN 100 SERIES CD stud drivers are easy to maintain and repair. Instruction sheets and parts lists are available upon request. If desired, TITAN TOOL COMPANY offers a prompt, economical repair service of your stud driver when returned to the factory

FIGURE 1:

100 SERIES CD STUD DRIVER
with #10 Gage

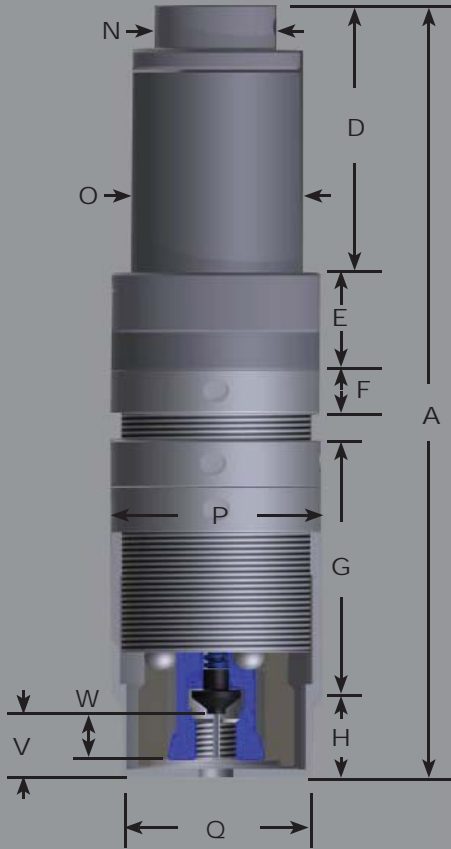

FIGURE 2:

100 SERIES CD STUD DRIVER
with Posi-Load Stud Retainer



Figure 1:

Tool shown in shortest position (with Jaws fully loaded and Gage set minimum setting.)

To allow for free movement of internal parts and collapsible Gage end when Jaws are in unloaded position, add the following to total tool length:

- #102 CD STUD DRIVER - 3/8" TO 1/2" (9.53mm to 12.7mm)
- #103 CD STUD DRIVER - 19/32" to 11/16" (15.08mm to 17.46mm)
- #104 CD STUD DRIVER - 9/16" to 7/8" (14.23mm to 22.23mm)

(Amount varies with position of stud driver - upright or inverted).

Any increase from the minimum gage setting causes an equal increase in dimensions A and V.

Figure 2:

Tool shown in shortest position (with Jaws fully loaded and with Posi-Load stud retainer).

To allow for free movement of internal parts and Posi-Load stud retainer when Jaws are in unloaded position, add the following to total tool length

- #102 CD STUD DRIVER - 17/32" TO 23/32" (13.5mm to 18.26mm)
- #103 CD STUD DRIVER - 13/16" to 15/16" (20.64mm to 23.81mm)
- #104 CD STUD DRIVER - 9/16" to 7/8" (Special to Order)

(Amount varies with position of stud driver - upright or inverted).

	DIMENSIONS	A	B	C	D	E	F	G	H	I	J	K
#102 CD	INCHES	8 5/16	8	8 21/32	2 23/32	1 1/8	1/2	2 3/8	13/16	1 9/16	2 1/8	5/8
	MILLIMETERS	211	203	220	69	29	13	60	21	40	54	16
#103 CD	INCHES	11 3/8	11	11 13/16	4 1/16	1	1 1/2	3 13/16	1 5/16	1 9/16	2 1/2	5/8
	MILLIMETERS	289	279	300	103	25	13	97	33	40	64	16
#104 CD	INCHES	13 7/8	13 1/8	14 1/4	4 21/32	1 1/8	1/2	4 5/8	1 15/16	-NA-	-NA-	23/32
	MILLIMETERS	352	333	362	118	29	13	117	49	-NA-	-NA-	18
	DIMENSIONS	L	M	N	O	P	Q	R	S	T	U	
#102 CD	INCHES	23/32	1 5/16	1 5/16	1 5/8	2	1 13/16	1 1/4	1 19/32	113/16	1 1/2	
	MILLIMETERS	18	33	33	41	51	46	32	40	46	38	
#103 CD	INCHES	1 3/16	1 15/16	1 13/16	2 3/16	2 11/16	2 1/2	2	2 5/32	2 1/2	2 1/32	
	MILLIMETERS	30	49	46	56	68	64	51	55	64	52	
#104 CD	INCHES	1 9/16	2 9/16	2 5/8	2 7/8	3 7/8	3 3/8	-NA-	-NA-	3 1/2	2 29/32	
	MILLIMETERS	40	65	67	73	98	86	-NA-	-NA-	89	74	

NOTE: All dimensions ± 1/32" or ± 0.8mm

WEIGHT: #102 CD 4 lbs., 8 oz.
#103 CD 11 lbs., 9 oz.
#104 CD 27 lbs., 12 oz.

FIGURE 3:

100 SERIES CD STUD DRIVER
less Posi-Load and Gage,
Jaws closed

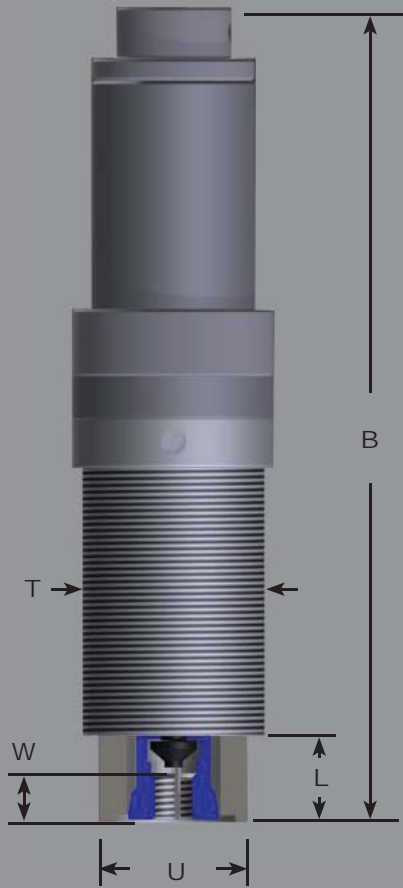

FIGURE 4:

100 SERIES CD STUD DRIVER
less Posi-Load and Gage,
Jaws open

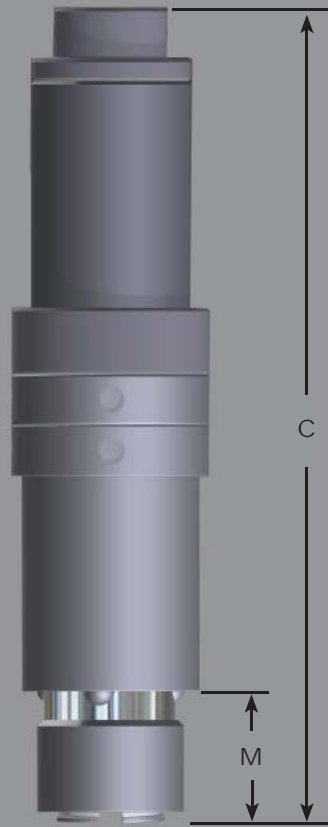

Figure 3 and 4:

Tools shown less Posi-Load and less Gage.

In certain cases the 100 SERIES CD CONTROLLED TORQUE STUD DRIVER may be run less these features. EXAMPLE: side interference does not provide sufficient clearance; (The stud must be hand started into casting when this occurs.)

To allow for free movement of internal parts when Jaws are in unloaded position, add the following:

#102 CD STUD DRIVER
+ 1/16" (1.57mm) - minus 0

#103 CD STUD DRIVER
+ 1/4" (6.35mm) - minus 0

#104 CD STUD DRIVER
+ 9/32" (7.14mm) - minus 0

(Amount varies with position of stud driver - upright or inverted).

STUD ENGAGEMENT FOR 100 SERIES CD STUD DRIVERS

		STUD SIZES	3/8 M10	7/16	1/2 M12	9/16 M14	5/8, 3/4, M16, M18, M20	7/8 M22	1", 1-1/8 M24, M27, M30
#102 CD	W	THREAD GRIP (ONLY)	INCHES	9/16	9/16	9/16	-	-	-
			MILLIMETERS	14	14	14	-	-	-
	V	TOTAL STUD ENGAGEMENT (WITH #10 GAGE OR POSI-LOAD)	INCHES	7/8	7/8	7/8	-	-	-
			MILLIMETERS	22	22	22	-	-	-
#103 CD	W	THREAD GRIP (ONLY)	INCHES	-	21/32	3/4	27/32	7/8	-
			MILLIMETERS	-	17	19	21	22	-
	V	TOTAL STUD ENGAGEMENT (WITH #10 GAGE OR POSI-LOAD)	INCHES	-	1	1 21/32	1 3/16	1 7/32	-
			MILLIMETERS	-	25	28	30	31	-
#104 CD	W	THREAD GRIP (ONLY)	INCHES	-	-	-	-	15/16	1 3/32
			MILLIMETERS	-	-	-	-	24	28
	V	TOTAL STUD ENGAGEMENT (WITH #10 GAGE ONLY)	INCHES	-	-	-	-	1 9/16	1 23/32
			MILLIMETERS	-	-	-	-	40	44

NOTE: All dimensions ± 1/32" or ± 0.8mm

IMPORTANT: For studs with thread lengths shorter than dimension "W", contact TITAN TOOL COMPANY for special modifications.

* For information on POSI-LOAD stud retainer for the #104 Cd stud driver, contact TITAN TOOL COMPANY.

FIGURE 1:

Tool prior to loading of jaws. Stud has been pre-loaded into POSI-LOAD stud retainer only. Jaws will load automatically when stud contacts casting. Tool should be rotating prior to stud contact with casting. (If stud is pre-started into casting, POSI-Load stud retainer is not necessary.)

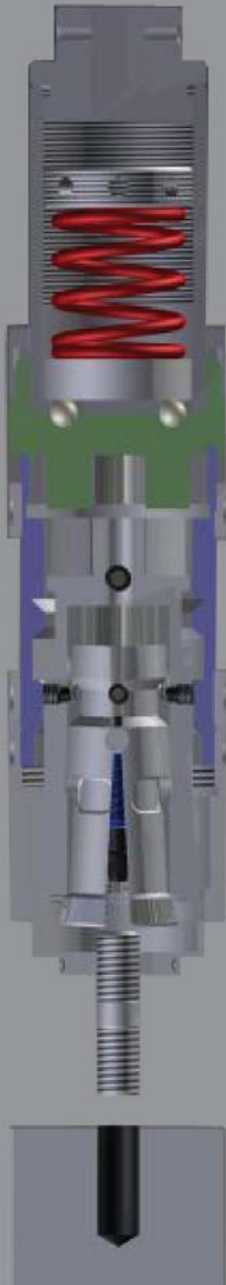
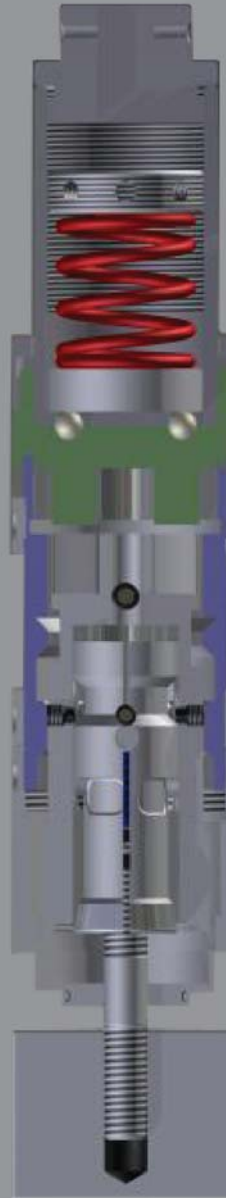

FIGURE 2:

Stud has been fully driven to shoulder on stud (or to bottom of hole.) Although jaws are still engaged on stud and the power source is still rotating, the clutch is over-running and the lower half of stud driver is stationary. Tool is ready to be lifted off stud, which will cause the jaws to open. (Spindle should be rotating continuously during drive and retraction cycles. Tool can be lifted off stud at anytime during drive cycle.)



100 SERIES CD® CONTROLLED-TORQUE STUD DRIVER

ORDERING INFORMATION CHART

TOOL SIZE	FEMALE ADAPTORS (Choose one)	CLUTCH SPRING (Choose one)	STUD SIZE (Choose one)		EQUIPPED WITH
			U.S.	METRIC	
#102 CD	3/8"-24 Threaded 1/2"-20 Threaded 5/8"-16 Threaded M16x1.00 Threaded 3/8" Square 1/2" Square	Medium 5-40 foot lbs. (Green) 6.8-54 NM 0.7-5.57 Kgm.	3/8"-16	M10 x 1.50 M10 x 1.25 M12 x 1.75 M12 x 1.25	#10 Gage (Standard) Posi-Load Stud Retainer (Optional)
			3/8"-24 7/16"-14 7/16"-20 1/2"-13 1/2"-20		
#103 CD	5/8"-16 Threaded 7/8"-14 Threaded 5/8" Square 3/4" Square	Medium 10-70 foot lbs. (Green) 13.6-95 NM 1.4-9.7 Kgm. Heavy 10-95 foot lbs. (Red) 13.6-129 NM 1.4-13.1 Kgm.	7/16"-14	M12 x 1.75 M12 x 1.25 M14 x 2.00 M14 x 1.50 M16 x 2.00	#10 Gage (Standard) Posi-Load Stud Retainer (Optional)
			9/16"-18 7/16"-20 1/2"-13 1/2"-20 3/4"-16		
#104 CD	1-1/4"-12 Threaded 3/4" Square 1" Square	Medium 10-150 foot lbs. (Green) 13.6-203 NM 1.4-20.7 Kgm. Heavy 25-225 foot lbs. (Red) 34-305 NM 3.5-31.1 Kgm.	5/8"-11	M16 x 2.00 M16 x 1.50 M18 x 2.50 M18 x 1.50 M20 x 2.50 M20 x 1.50 M22 x 2.50	#10 Gage (Standard) Posi-Load Stud Retainer (Special to Order)
			5/8"-18 3/4"-10 3/4"-16 7/8"-9 7/8"-14		

EXAMPLES FOR ORDERING:

(Assume 1/2" or 3/4" Male Square on power tool.)

- A. 3/8"-24 stud to be pre-loaded into #102 CD and driven to shoulder at 30' lbs. torque.
Specify: #102 CD, 3/8"-24, Medium Spring, 1/2" Female Square
- B. M14 x 2.00 stud to be hand started into casting and driven to bottom of hole at 6.9 Kgm.
Specify #103 CD, M14 x 2.00, #10 Gage, Medium Spring, 3/4" Female Square.

SHANKS ARE AVAILABLE UPON REQUEST

WHEN ORDERING:

TITAN TOOL COMPANY has specialized in stud driving since 1920. We offer many years of experience in this field. We encourage you to contact us before proceeding with any new set-ups involving our tools. Our service is prompt and free of charge.

IMPORTANT:

- SEND COMPLETED "CUSTOMER SPECIFICATION SHEET" WITH ORDER
- INCLUDE SAMPLE STUD WITH ORDER
- DO NOT USE ON IMPACT WRENCH

SPRING LOAD NECESSITY

IMPORTANT - On all single and multiple spindle applications:

- Always mount tools on spring-loaded spindles - otherwise, tool life and performance will be adversely effected
- Refer to literature on the TITAN TTSL series of spring loaded adaptors.

PROJECTION HEIGHT REQUIRED?

CONSIDER THE TITAN 100 SERIES AUTOMATIC

Note the position of stud:
Even though stud has been driven to a required projection height, it has not been driven to bottom of tapped hole, and threads are still visible above surface on casting end of stud. The TITAN 100 SERIES AUTOMATIC with "Trip Gage" is designed specifically for this purpose. Please refer to the TITAN 100 SERIES AUTOMATIC Brochure for details on this type of application.



TITAN® TOOL COMPANY, INC.

7410 West Ridge Road • P.O. Box 220 • Fairview, PA 16415

Phone (814) 474-1583 • FAX (814) 474-5337 • Email: titan@titantoolco.com