

TITAN TOOL

TITAN MODEL R[®] SERIES PIPE DRIVER AND REMOVER

- Specifically designed to drive or remove hollow pipe nipples
- Rapid push on and pull off design
- Uses a series of hardened ground rolls to grasp the outside diameter of the pipe
- Quick releasing
- Positive drive, will not slip
- Can be used with a TITANTORKER for accurate torque control
- Ideal for hand held applications
- Available for pipe sizes from 3/8" through 1 1/2"



TITAN MODEL R[®] PIPE DRIVER AND REMOVER

HOW THE MODEL-R WORKS:

When the MODEL R is loaded onto a pipe the smoothly ground tapered rolls wedge themselves between the internal crescent shaped cams of the main ring and the outside diameter of the pipe. Any rotational motion will cause the drive rolls to increase their grip on the pipe thus rotating it in the desired direction. When rotation stops the tool is simply pulled away from the pipe.

The MODEL R is designed to be able to pass over the standard length threads on the end of most pipes, allowing the driver to contact the unthreaded body of the pipe nipple. If marking of the threads is a critical concern for your application, please make certain to send a sample of your pipe to TITAN for examination.

WHEN ORDERING PLEASE INDICATE:

- The pipe size you are using
- Required drive square size
- Amount of thread on the end of the pipe inserted into the MODEL R
- Type of power tool to be used
- Amount of pipe nipple protruding from workpiece when it is fully driven
- Dimensions of any interference problems which might present a problem to the MODEL R

PIPE SIZE	DRIVE SQUARE	TOOL NUMBER
3/8"	1/2"	MDRPDVR01-SQ5
1/2"	1/2"	MDRPDVR02-SQ5
3/4"	1/2"	MDRPDVR03-SQ5
3/4"	3/4"	MDRPDVR03-SQ7
1"	1/2"	MDRPDVR04-SQ5
1"	3/4"	MDRPDVR04-SQ7
1 1/4"	3/4"	MDRPDVR05-SQ7
1 1/2"	3/4"	MDRPDVR06-SQ7

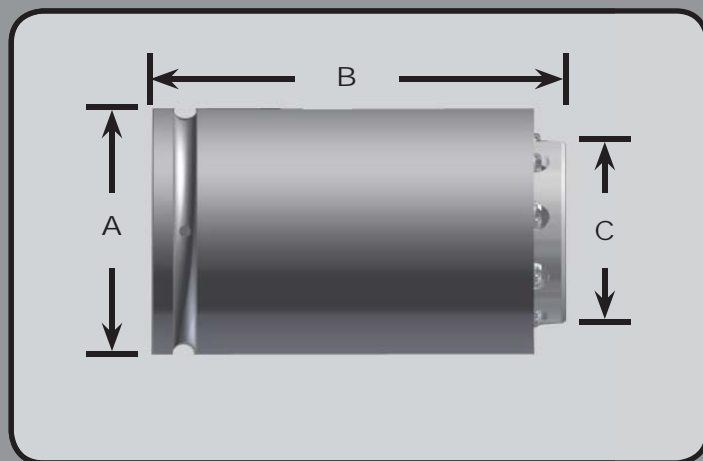

PIPE SIZE	A	B	C	WEIGHT
3/8"	1 13/16"	3 7/16"	1 5/64"	2 LBS.
1/2"	2"	3 7/16"	1 15/64"	2.4 LBS.
3/4"	2 1/4"	3 5/8"	1 15/32"	3.1 LBS.
1"	2 7/8"	4 1/4"	1 13/16"	6 LBS.
1 1/4"	3 5/16"	4 7/8"	2 5/32"	9.1 LBS.
1 1/2"	3 5/8"	5 1/16"	2 13/32"	11.2 LBS.

IMPORTANT - INCLUDE SAMPLE STUD WITH ORDER



TITAN[®] TOOL COMPANY, INC.

7410 West Ridge Road • P.O. Box 220 • Fairview, PA 16415

Phone (814) 474-1583 • FAX (814) 474-5337 • Email: titan@titantoolco.com