

MUSTANG[®] STUD DRIVER

- Positive drive, will not slip
- For applications where restricted space does not allow larger diameter automatic stud drivers
- Loose plunger design assures quick release of stud upon reversal of spindle
- Ideal for hand held, semi or fully automatic machines
- Easily adjustable for different lengths of thread engagement
- Available in two sizes for studs from #10 through 9/16" and M5 through M14
- Can be used in conjunction with a TITANTORKER[®] or TORQUETTE[®] torque control applications



MUSTANG® STUD DRIVER

The TITAN MUSTANG is designed to drive studs where both a limited space demands a small tool diameter, and an adjustable length of stud engagement is desired. Adjustment of the stud engagement is positive, cannot slip or come loose, and requires no wrenches or tools of any kind.

The MUSTANG's "loose plunger" design allows the drive head to back away instantly upon reversal of power tool, thereby eliminating all pressure, allowing the sleeve to unthread freely from the driven stud.

Use with T-Handle, or any reversible power tool except impact wrench.

Easily adapts to Titan "TitanTorker" or "Torquette" for applications requiring torque control.

All parts are made of high alloy steel, specially heat treated and are independently replaceable.

To adjust length of stud engagment:

Lift the clutch ring above the hex and turn the driving head RIGHT for *less* grip on the stud. Turn the driving head LEFT for *more* grip on the stud.

Caution:

Do not shorten grip to the point where sleeve cannot rotate freely.

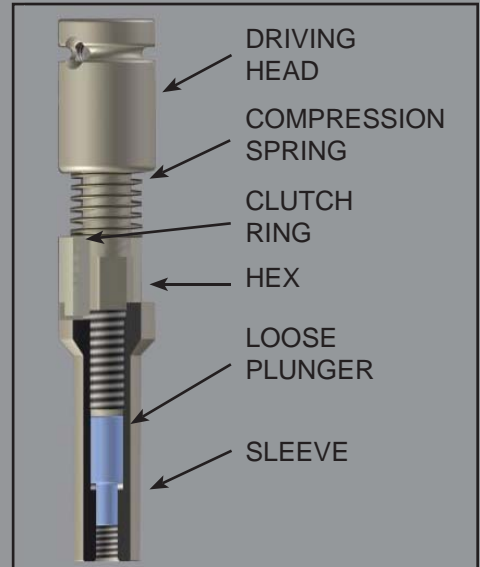

TOOL NUMBERS

TOOL SIZE	U.S.			METRIC		
	STUD SIZE	3/8" Female Square Drive	1/2" Female Square Drive	STUD SIZE	3/8" Female Square Drive	1/2" Female Square Drive
MUSTANG-1	#10-24	M1-SQ3-01	M1-SQ5-01	M5 x .8	M1-SQ3-09	M1-SQ5-09
	#10-32	-02	-02	M6 x 1.00	-10	-10
	1/4"-20	-03	-03	M7 x 1.00	-11	-11
	1/4"-28	-04	-04	M8 x 1.25	-12	-12
	5/16"-18	-05	-05	M8 x 1.00	-13	-13
	5/16"-24	-06	-06	M10 x 1.50	-14	-14
	3/8"-16	-07	-07	M10 x 1.25	-15	-15
3/8"-24	-08	-08				
MUSTANG-2	3/8"-16	-	M2-SQ5-01	M10 x 1.50	-	M2-SQ5-09
	3/8"-24	-	-02	M10 x 1.25	-	-10
	7/16"-14	-	-03	M12 x 1.75	-	-11
	7/16"-20	-	-04	M12 x 1.25	-	-12
	1/2"-13	-	-05	M14 x 2.00	-	-13
	1/2"-20	-	-06	M14 x 1.50	-	-14
	9/16"-12	-	-07			
9/16"-18	-	-08				

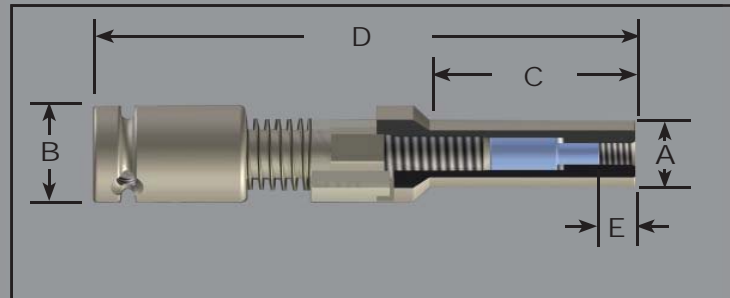

TOOL SIZE	A	B	C	D	E	WEIGHT
MUSTANG-1	11/16"	1"	1 15/16"	5 1/16"	Adjustable (Min. One Stud Dia.)	.75 lb
MUSTANG-2	1"	1 3/8"	2 3/8"	6 11/16"		1.9 lbs.

NO.	T-HANDLE SIZE
TEE-SQ3	10" T-HANDLE WITH 3/8" MALE SQUARE
TEE-SQ5	11" T-HANDLE WITH 1/2" MALE SQUARE



TITAN® TOOL COMPANY, INC.

7410 West Ridge Road • P.O. Box 220 • Fairview, PA 16415
 Phone (814) 474-1583 • FAX (814) 474-5337 • Email: titan@titantoolco.com