

TITAN TOOL

TITAN PACTOR™

- Designed for applications calling for “Impact Wrench” driving, but studs are not “Bottoming or Shouldering”
- Designed with “Pressure Plate and Internal Bushing” to assure unloading upon reverse of power tool, even on “low reversal torque” applications
- Designed TOUGH to withstand high driving torques



TITAN PACTOR™ STUD DRIVER

Std. Female Square Drive
 Model 875 3/4" or 1"
 Model 1250 3/4" or 1"

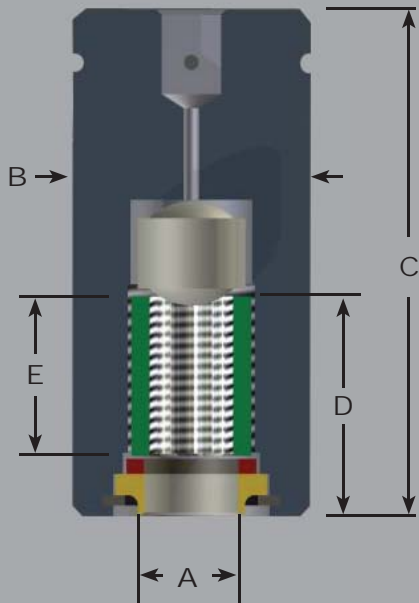

**IF YOU DRIVE STUDS
 WITH AN IMPACT WRENCH
 AND LOW REVERSAL TORQUE
 IS A KEY FACTOR -
 JUST CALL TITAN AND
 ORDER A PACTOR!**

**PROVEN TIME AFTER TIME AS THE
 "PROBLEM SOLVER FOR STUD DRIVING"**

STUD SIZE	TOOL NO.		PHYSICAL DIMENSIONS					WEIGHT
	3/4" FEMALE DRIVE SQUARE	1" FEMALE DRIVE SQUARE	A	B	C	D	E	
5/8"-11 5/8"-18	#875-01 875-02	#875-07 875-08	5/8"	2 3/8"	4 5/8"	1 9/16"	11/16"	5 LBS.
3/4"-10 3/4"-16	875-03 875-04	875-09 875-10	3/4"					
7/8"-9 7/8"-14	875-05 875-06	875-11 875-12	7/8"					
1"-8 1"-12 1"-14	#1250-01 1250-02 1250-03	#1250-10 1250-11 1250-12	1"	2 3/4"	4 15/16"	1 7/8"	1"	7 LBS.
1 1/8"-7 1 1/8"-8 1 1/8"-12	1250-04 1250-05 1250-06	1250-13 1250-14 1250-15	1 1/8"					
1 1/4"-7 1 1/4"-8 1 1/4"-12	1250-07 1250-08 1250-09	1250-16 1250-17 1250-18	1 1/4"					

Made in two sizes to accommodate most NC and NF threaded studs.
 (Also available special to order in common METRIC sizes.)

All parts easily replaceable - refer to Tool and Parts Price List, available on request

IMPORTANT - INCLUDE SAMPLE STUD WITH ORDER



TITAN® TOOL COMPANY, INC.

7410 West Ridge Road • P.O. Box 220 • Fairview, PA 16415

Phone (814) 474-1583 • FAX (814) 474-5337 • Email: titan@titantoolco.com