

TITAN TOOL

TITAN TTSL[®] SPRING LOADED SPINDLE ADAPTOR

- Rugged Design
- Long lasting
- Low maintenance
- Easily adjusted for different torque
- Designed to provide optimal performance from TITAN stud drivers
- Absorbs excess spindle travel while maintaining axial pressure between spindle and stud driver
- Easily attaches to stud drivers, sockets, and shafts
- A must for all multi-spindle machines
- Available in three sizes
- Will handle torque loads up to 350 foot pounds or 475 NM



TITAN TTSL® SPRING LOADED SPINDLE ADAPTOR

While many companies offer devices to allow axial compliance or spring load between a machine spindle and its attachments, Titan Tool Company is the only manufacturer to design and manufacture an adaptor specifically designed for use on fully automatic stud drivers.

How does the TTSL® differ from more generic devices? The TTSL® offers a wide variety of female adaptors and male shanks, making the TTSL® adaptable to virtually every machine spindle and application. The TTSL® incorporates a hardened, precision ground collet and drive system to maximize allowable torque and minimize eccentricity and run-out. While most generic adaptors use light weight compression springs that work well on sockets and screw driver bits, they are not sufficient for use with stud drivers. The compression springs of the TTSL® have been specifically selected to yield optimum performance with Titan stud drivers. Every component of the TTSL® has been meticulously designed, manufactured, and tested to provide years of trouble free operation.

Decades of experience have proven the value, quality, and performance advantages of the TTSL®. If your automatic or multiple spindle application demands peak performance from your stud drivers, don't settle for anything less.

When driving studs with an automatic stud driver it is essential to increase the axial pressure of the spindle in direct relationship to the torque being applied to the stud. The compression springs used in the TTSL® are designed to have a linear compression rate, which is ideally suited for this purpose.



To get optimum performance from your stud driver, spindle travel should be approximately 10% faster than the speed at which the stud penetrates into the work piece. **This will cause the axial pressure of the spindle to increase as the installation torque increases.** The TTSL® should be used to absorb this excess feed, but care must be taken to prevent the TTSL® from becoming completely compressed. This will negate many of the advantages of a spring load.

It is also essential for the correct operation of the stud driver that the TTSL® **not be used to continue the advancement of the stud driver after the spindle drive mechanism has been halted.** Doing so would cause the axial pressure of the spindle to decrease as driving torque increases, thus causing performance problems with the stud driver.

TTSL MODEL	MAXIMUM ALLOWABLE TORQUE	SPRING PRESSURE AT FULL COMPRESSION
TTSL-00	20 FT/LBS - 27.12 NM	50 LBS - 11.5 Kg
TTSL-1	95 FT/LBS - 128.82 NM	22 LBS - 9.1 Kg LIGHT 65 LBS - 29.5 Kg MEDIUM 120 LBS - 54.5 Kg HEAVY
TTSL-3	350 FT/LBS - 476.6 NM	110 LBS - 55Kg

TITAN TTSL® PHYSICAL DIMENSIONS AND OPTIONS

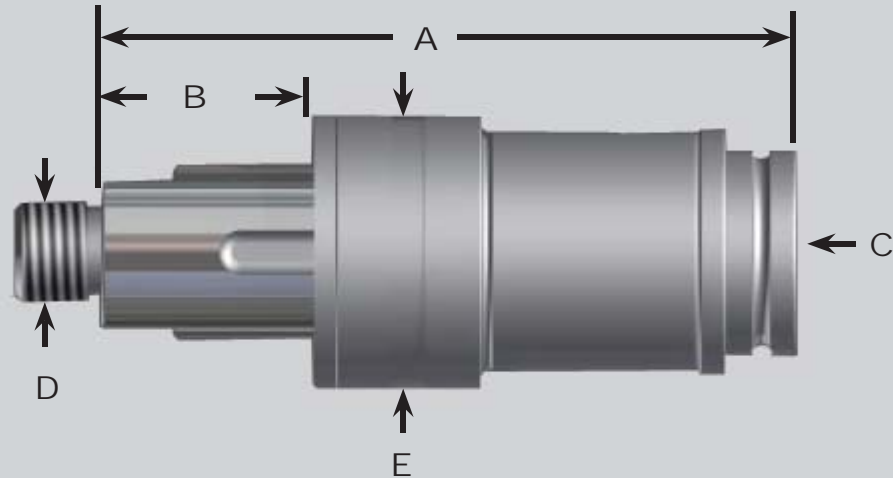

MODEL NUMBER	A	B	C	D	E	WEIGHT	AVAILABLE COMPRESSION SPRINGS
TTSL-0	4 5/32" 105.7 mm	1 1/16" 27 mm	3/8" SQ. M14 x 1.00 3/8"-24 1/2"-20 5/8"-16	3/8"-24	1.150" 29.2 mm	.625 lb. .284 Kg.	STANDARD
TTSL-1	4 1/8" 104.8 mm	1 1/32" 26.2 mm	3/8" SQ. 1/2" SQ. 3/8"-24 1/2"-20 5/8"-16 M14 x 1.00 M16 x 1.00	3/8" or 1/2" SQ with thru hole 1/2" SQ. with pin lock 1/2"-20 5/8"-16 M14 x 1.00 M16 x 1.00	1.562" 39.7 mm	1.125 lbs. .510 Kg.	LIGHT MEDIUM HEAVY (standard)
TTSL-3	6 5/32" 156.4 mm	1 7/8" 47.6 mm	5/8" SQ. 3/4" SQ. 5/8"-16 7/8"-14	3/4" SQ. with thru hole 7/8"-14 1 1/4"-12	2.437" 61.9 mm	4.625 lbs 2.1 Kg.	STANDARD

All dimensions are ± 0.032"/0.8mm

* All tools will be shipped with standard springs unless otherwise specified



TITAN® TOOL COMPANY, INC.

7410 West Ridge Road • P.O. Box 220 • Fairview, PA 16415

Phone (814) 474-1583 • FAX (814) 474-5337 • Email: titan@titantoolco.com