

VICTORY SERIES® STUD REMOVERS

- Ideal for hand held applications
- Can be used with many power tools
- Stud is gripped by threaded jaw mechanism, eliminating damage to the stud
- Can be used to remove studs or to check back-out torque
- Available in three sizes
- Will handle studs from #10 through 3/4"



VICTORY SERIES® STUD REMOVERS

STUD SIZE	DRIVE SQUARE	STUD SWALLOW	PART NUMBER
#10-24	1/2"	0.325"	V#8-SQ5-01
#10-32	1/2"	0.325"	V#8-SQ5-02
1/4"-20	1/2"	0.370"	V#8-SQ5-03
1/4"-28	1/2"	0.370"	V#8-SQ5-04
5/16"-18	1/2"	0.430"	V#8-SQ5-05
5/16"-24	1/2"	0.430"	V#8-SQ5-06
3/8"-16	1/2"	0.430"	V#8-SQ5-07
3/8"-24	1/2"	0.430"	V#8-SQ5-08
M6 x 1.00	1/2"	0.370"	V#8-SQ5-09
M8 x 1.25	1/2"	0.430"	V#8-SQ5-12
M10 x 1.00	1/2"	0.430"	V#8-SQ5-13
7/16"-14	1/2"	0.475"	V#88-SQ5-01
7/16"-20	1/2"	0.475"	V#88-SQ5-02
1/2"-13	1/2"	0.530"	V#88-SQ5-03
1/2"-20	1/2"	0.530"	V#88-SQ5-04

ITEM	QTY	DESCRIPTION	PART #
1	1	DRIVE RETENTION SCREW	SCR-100
2	1	MAIN RING	V#8-MR V#88-MR
3	1	MAIN RING ASSEMBLY SCREW	SCR-115
4-11		COMPLETE JAW AND CORE ASSEMBLY INCLUDES ITEMS 4-10 FOR: #10-32 V#8-JCA-01 #10-24 V#8-JCA-02 1/4"-20 V#8-JCA-03 1/4"-28 V#8-JCA-04 5/16"-18 V#8-JCA-05 5/16"-24 V#8-JCA-06 3/8"-16 V#8-JCA-07 3/8"-24 V#8-JCA-08 M6 x1.00 V#8-JCA-09 M8 x 1.25 V#8-JCA-12 M10 x 1.00 V#8-JCA-13 7/16"-14 V#88-JCA-01 4/16"-20 V#88-JCA-02 1/2"-13 V#88-JCA-03 1/2"-20 V#88-JCA-04	

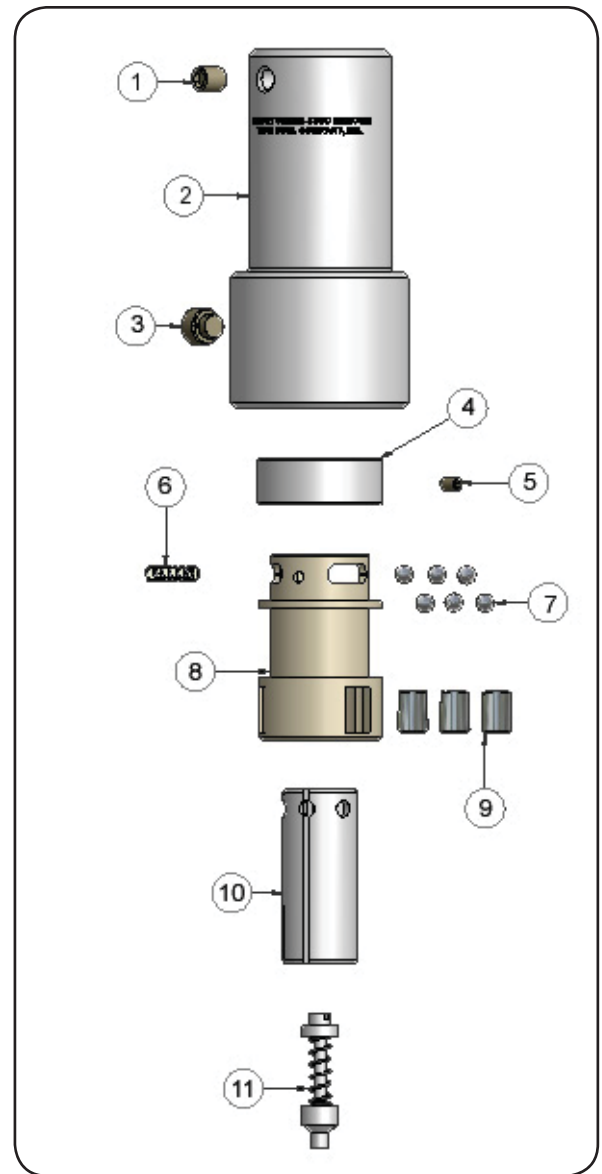

DUE TO THE SELECT FIT OF THESE COMPONENTS AND THE COMPLEXITY OF THE ASSEMBLY, ITEMS 4-11 MAY ONLY BE PURCHASED AS AN ASSEMBLY.

IMPORTANT - INCLUDE SAMPLE STUD WITH ORDER



TITAN® TOOL COMPANY, INC.

7410 West Ridge Road • P.O. Box 220 • Fairview, PA 16415
 Phone (814) 474-1583 • FAX (814) 474-5337 • Email: titan@titantoolco.com