

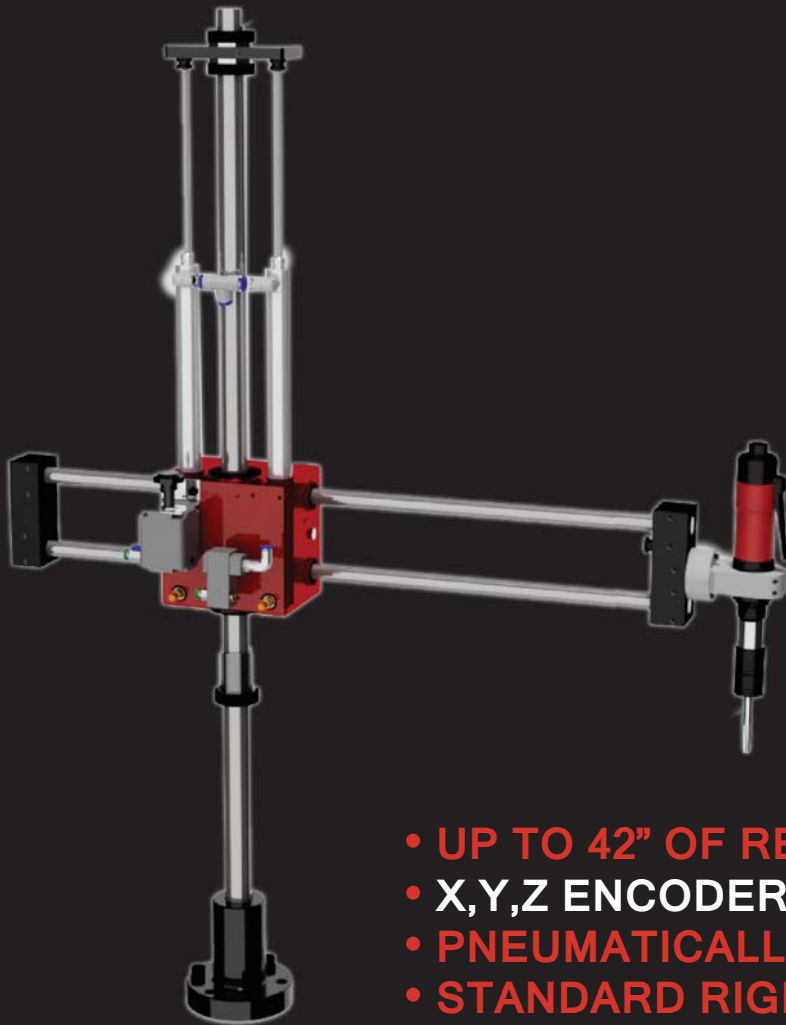

TITANMATE® LINEAR SERIES

The **TITANMATE**® LINEAR SERIES starts as a single billet of aluminum. It is then CNC machined to house precision bearings. Available in three sizes, the linear series arms can be used in high torque to delicate assembly processes.



- UP TO 42" OF REACH
- X,Y,Z ENCODERS AVAILABLE
- PNEUMATICALLY ADJUSTABLE
- STANDARD RIGID TOOL MOUNT
- PRECISION STAINLESS BEARINGS
- CNC MACHINED BEARING HOUSING



TITAN TOOL COMPANY, INC.

7410 WEST RIDGE ROAD • FAIRVIEW, PA 16415

814.474.1583 - TEL

814.474.5337 - FAX

www.titantoolco.com



TITANMATE® LINEAR SERIES SPECIFICATIONS

TML2 SERIES:

PAYLOAD - 10LBS.
TORQUE CAPACITY - 35 ft/lbs. (47Nm)

TML3 SERIES:

PAYLOAD - 30LBS.
TORQUE CAPACITY - 75 ft/lbs. (101Nm)

TML4 SERIES:

PAYLOAD - 50LBS.
TORQUE CAPACITY - 100 ft/lbs. (136Nm)

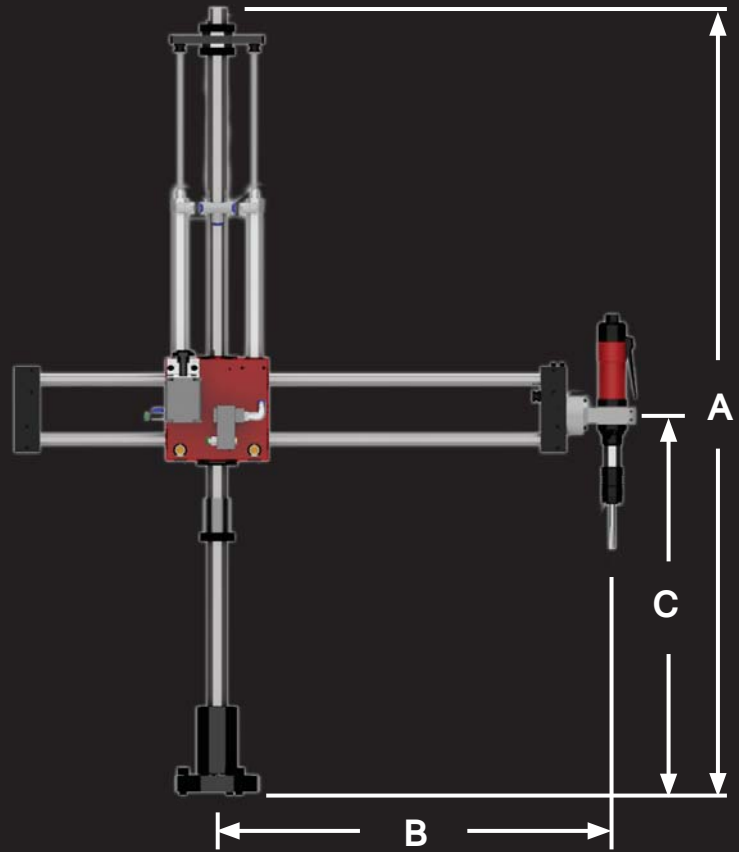

MODEL	A	B	C
TML2.5	36" (914mm)	7"-23" (178mm-584mm)	18" (457mm) - MAX 7.5" (190mm) - MIN
TML3	42" (1066mm)	7"-30" (178mm-762mm)	20" (508mm)- MAX 7" (190mm) - MIN
TML4	48" (1320mm)	14"-45" (356mm-1143mm)	26" (572mm) - MAX 7.5" (190mm) - MIN

CUSTOM LENGTH HORIZONTAL RAILS AND VERTICAL SHAFTS ARE AVAILABLE.



TITANMATE® OPTIONAL EQUIPMENT

TITANLITE (TLAR-137):

- Multi-positional tool mount
- Swivel tool mount (for horizontal assembly)
- Bellville washers (for locking pivot)
- Right angle tool mount

TMAR4 SERIES:

- Multi-positional tool mount
- Swivel tool mount (for horizontal assembly)
- **LIFTING ARM CONVERSION (up to 250 lbs. capacity)**
- Right angle tool mount
- **HIGH TORQUE ARM (up to 1000Nm)**
- Drilling arm conversion
- Bellville washers (for locking pivot)
- **Complete tapping package (air tool, chuck, tap collets)**

TMAR2-X55:

- Multi-positional tool mount
- Right angle tool mount
- **Complete tapping package (air tool, chuck, tap collets)**
- Swivel tool mount (for horizontal assembly)
- Bellville washers (for locking pivot)

TMAR4-X80:

- Multi-positional tool mount
- Right angle tool mount
- **HIGH TORQUE ARM (up to 1000Nm)**
- Swivel tool mount (for horizontal assembly)
- Bellville washers (for locking pivot)
- **Complete tapping package (air tool, chuck, tap collets)**

TMAR2 SERIES:

- Multi-positional tool mount
- Swivel tool mount (for horizontal assembly)
- **Complete tapping package (air tool, chuck, tap collets)**
- Right angle tool mount

TML2.5 SERIES:

- Multi-positional tool mount
- Swivel tool mount (for horizontal assembly)
- **Complete tapping package (air tool, chuck, tap collets)**
- Right angle tool mount

TML3 & TML4 SERIES:

- Multi-positional tool mount
- Swivel tool mount (for horizontal assembly)
- **Complete tapping package (air tool, chuck, tap collets)**
- Right angle tool mount
- **X,Y,Z ENCODERS**

We accept many custom applications. If you do not see an option listed, please contact Titan Tool Company, Inc.



TITAN TOOL COMPANY, INC.

7410 WEST RIDGE ROAD • FAIRVIEW, PA 16415

814.474.1583 - TEL

814.474.5337 - FAX

www.titantoolco.com